

STEAM TURBINES



STEAM TURBINES

Efficient, flexible and reliable machines

Steam turbines are the foundations on which Ansaldo was built: the Company was established in 1853 to support to the development of the then-flourishing **steam locomotive industry**.

Ansaldo Energia long-standing experience on steam covers the design, manufacturing and installation of steam engines: the overall unit amount is about 700 worldwide with a total capacity of nearly 100 GW.

Today's **Ansaldo Energia steam turbine portfolio** has been developed for application in most power generation technologies, from traditional fossil combustion to renewable energy:

- **Steam Power** and **Combined Cycle plants**
- **District heating, cogeneration, desalinization** and **solar power** facilities, as well as **nuclear plants**

Current production includes:

- **Large ratings** for reheat applications, respecting the highest steam parameters for supercritical and ultra-supercritical conditions
- **Compact modules** for smaller ratings
- **Single** and **two-cylinders** models for non-reheat thermal cycles
- **Geothermal** steam turbines, based on impulse design

Each steam turbine model is a combination of **pre-engineered, well-proven modules** of different sizes, providing a broad range of power ratings and applications in both **50 and 60 Hz** markets. Modular design reduces both technical development and manufacturing time.

All models are **assembled in our workshop** – except the large low-pressure sections, which are most conveniently field-installed.

Type	Series	Power range (MW)	Application
REHEAT	RT30 MT15	150-1,000 100-300	Combined Cycle, Fossil, Cogeneration Combined Cycles, Fossil, Solar
NON-REHEAT	MT20 MT10	100-350 40-250	Combined Cycle, Fossil, Cogeneration Combined Cycle, Fossil, Solar
GEOHERMAL	GT	15-150	Geothermal
NUCLEAR	MT10/MT20/ RT30	100-800	Small Modular Reactor (SMR)

Steam Turbines portfolio

REHEAT

Efficient and flexible

Reheat steam turbines increase **efficiency** by returning partially-expanded steam to the steam generator for reheating before feeding it back to the turbine.

The Ansaldo Energia reheat steam turbines portfolio includes machines from **two to five cylinders**, capable of covering a wide range of steam cycles, site conditions and operating modes.

For **small ratings**, the design concept is based on two cylinders with single-flow exhaust.

For **higher ratings**, the design is based on separate high-pressure and intermediate-pressure sections with one (or more) double-flow low-pressure sections. This configuration is suitable for Combined Cycles with advanced F- and H- class gas turbines as well as fossil power plants with the highest steam parameters for **supercritical/ultra-supercritical** conditions.

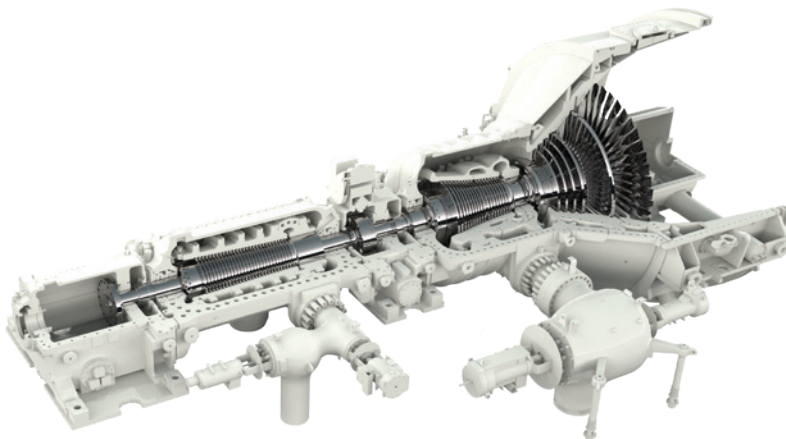

MT15: reheat reaction steam turbine, two cylinders.

Advanced technology features

The design reflects the following distinctive advanced technology features:

- 3D stationary and rotating blades are based on **reaction** robust design, manufactured from bar stock with airfoil integral with the dovetail and covers
- Shrink rings on the high-pressure inner casing allowing **compact** and **uniform** shape for superior **thermal flexibility** and **cycling capability**
- **Single bearing** design, with bearings directly sitting on the foundation, ensuring optimum rotor behavior and compact overall dimensions
- **Welded rotors** for higher thermal flexibility and optimum material selection
- **Axial** or **downward exhaust** for single flow configuration and **side** or **downward exhaust** for double flow configuration
- **Synchro-Self-Shifting Clutch** for connection to the generator, in single-shaft application, providing higher operating flexibility as a result of independent operations between gas and steam turbines

Series	MT15	RT30
Application	Medium Reheat CC or Fossil-fired Steam Cycles, Cogeneration and Solar plants	Large Reheat CC or Fossil-fired Steam Cycles, Cogeneration and Solar plants
Steam parameters	Up to 170 bar Up to 600°C / 585°C	Up to 280 bar Up to 600°C / 620°C
Configuration	Two cylinders with single flow exhaust	Three or more cylinders with double flow LP section(s)

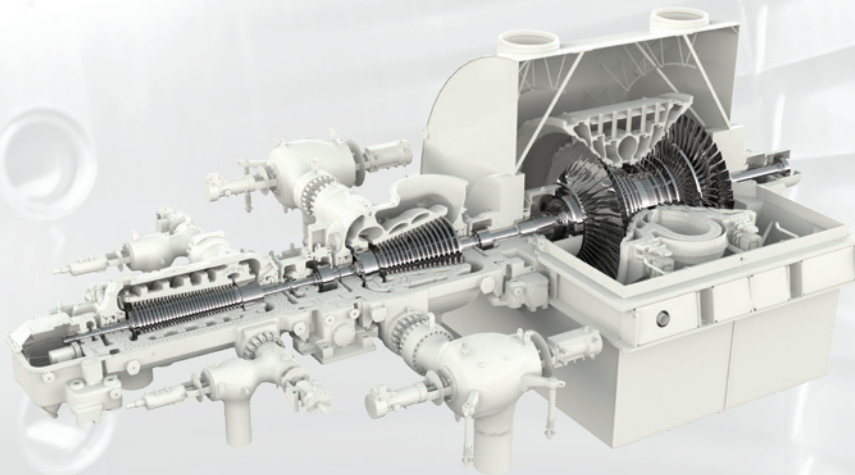

RT30: reheat reaction steam turbine, three cylinders.

NON REHEAT

Compact and reliable

Non-reheat turbines are the solution which best suits the needs of **industrial plants** and **small utilities**.

The Ansaldo Energia non-reheat steam turbines portfolio includes machines from one to three cylinders, capable of covering a wide range of steam cycles, site conditions and operating modes.

For **small ratings**, a compact single cylinder machine, consisting of a combined high-pressure/low-pressure section is the natural solution.

For **higher ratings**, the design concept is based on two or more cylinders: a high-pressure section and one (or more) double-flow low-pressure sections, depending on exhaust conditions. In combined cycle, features can be adapted for different gas turbine configurations and steam conditions.

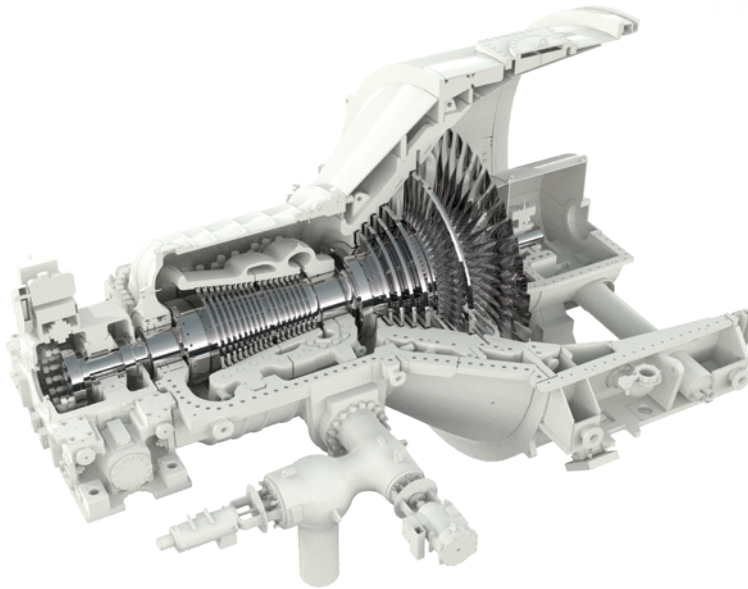

MT10: non-reheat steam turbine.

Advanced technology features

The design reflects the following distinctive advanced technology features:

- 3D stationary and rotating blades are based on **reaction robust design** and manufactured from bar stock with the airfoil integral with the dovetail and covers
- The **single bearing** design, with bearings directly sitting on the foundation, ensuring optimum rotor behavior and compact overall dimensions
- **Welded rotors** for higher thermal flexibility and optimum material selection
- **Axial** or **downward exhaust** for single flow configuration and **side** or **downward exhaust** for double flow configuration
- **Synchro-Self-Shifting Clutch** for connection to the generator, in single-shaft application, providing higher operating flexibility as a result of independent operations between gas and steam turbines

Series	MT10	MT20
Application	Small non reheat CC, Condensing or backpressure, Cogeneration	Medium and Large non reheat CC Cogeneration
Steam parameters	Up to 140 bar Up to 565°C	Up to 140 bar Up to 565°C
Configuration	Single cylinder with single flow exhaust	Two or more cylinders with double flow LP section(s)

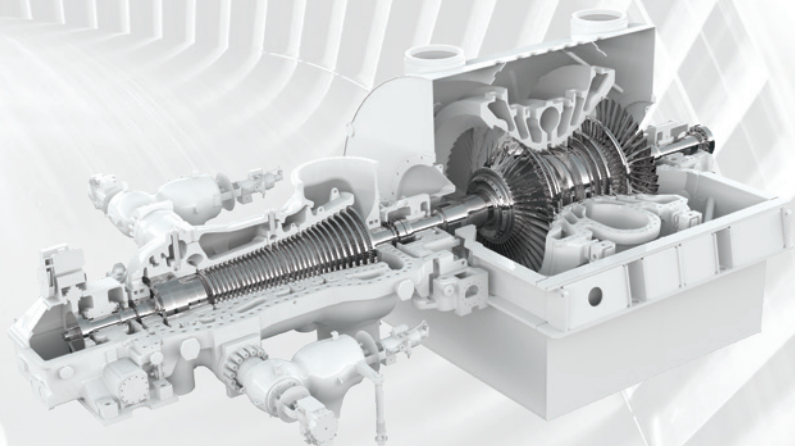

MT20: non-reheat combined cycle application.

GEOTHERMAL

Energy from the heat of the earth

Ansaldo Energia's first turbine-generator units driven by geothermal steam went in operation in Larderello (Italy) in 1911, powering what is considered **the first geothermal power plant in the world** – a milestone in the history of renewables.

Current Ansaldo Energia portfolio is based on **impulse technology** and includes machines from one cylinder in single-flow configuration to two cylinders in double-flow configuration, with different exhaust solutions to suit plant layout requirements.

Top, lateral, axial discharge to the condenser are available in addition to the conventional vertical downward setup.

Thanks to Ansaldo Energia's century-long experience and specific geothermal know-how, GT steam turbines guarantee **high reliability** and **durability** despite the harsh environment in which they operate – characterized by high levels of moisture, dissolved salts and acids. Special materials are used for rotor and blades to minimize the impact of corrosive chemicals.

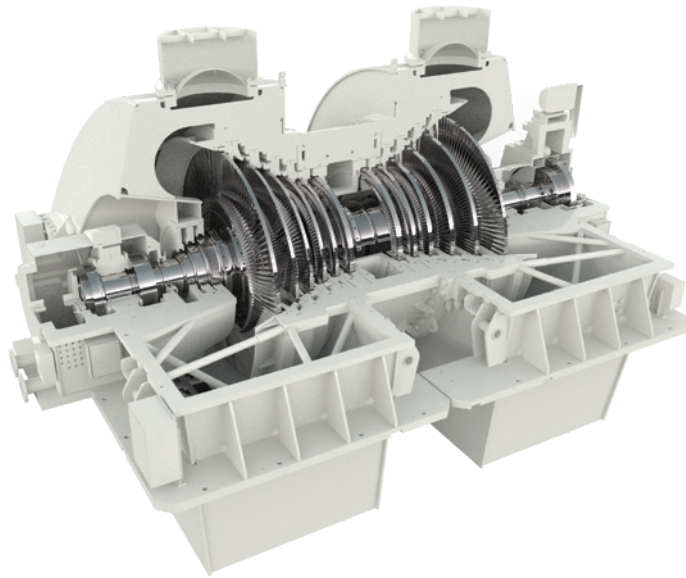

GT: geothermal steam turbine.

Advanced technology features

The design reflects the following distinctive advanced technology features:

- **Impulse** technology with new generation of airfoil and sealing
- Admission steam valves are of **butterfly** type
- **Special materials** are used for rotor and blades, in order to minimize the impact of salt deposits and acid attach on the reliability of the fleet
- A large selection of **last stage blades**, ranging from 20" to 31" are available to match at best the proper steam characteristic of the specific geothermal field
- **Downward, upward, axial** or **lateral** different **exhaust** configurations to the condenser are all available, to ensure the maximum flexibility to any Customer's need

Series	MT10
Application	Geothermal cycles
Steam parameters	Up to 20 bar Up to 10°C superheated
Configuration	Single cylinder up to two cylinders



For more information,
please visit
www.ansaldoenergia.com

Follow us on LinkedIn 
[www.linkedin.com/company/
ansaldo-energia](https://www.linkedin.com/company/ansaldo-energia)

